

A

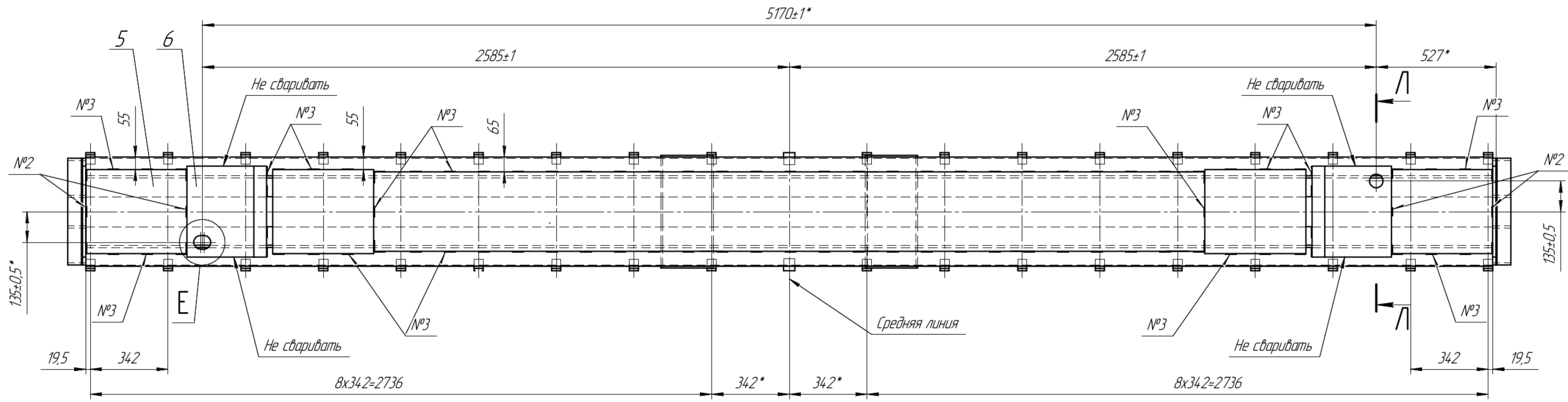

B(1:1)

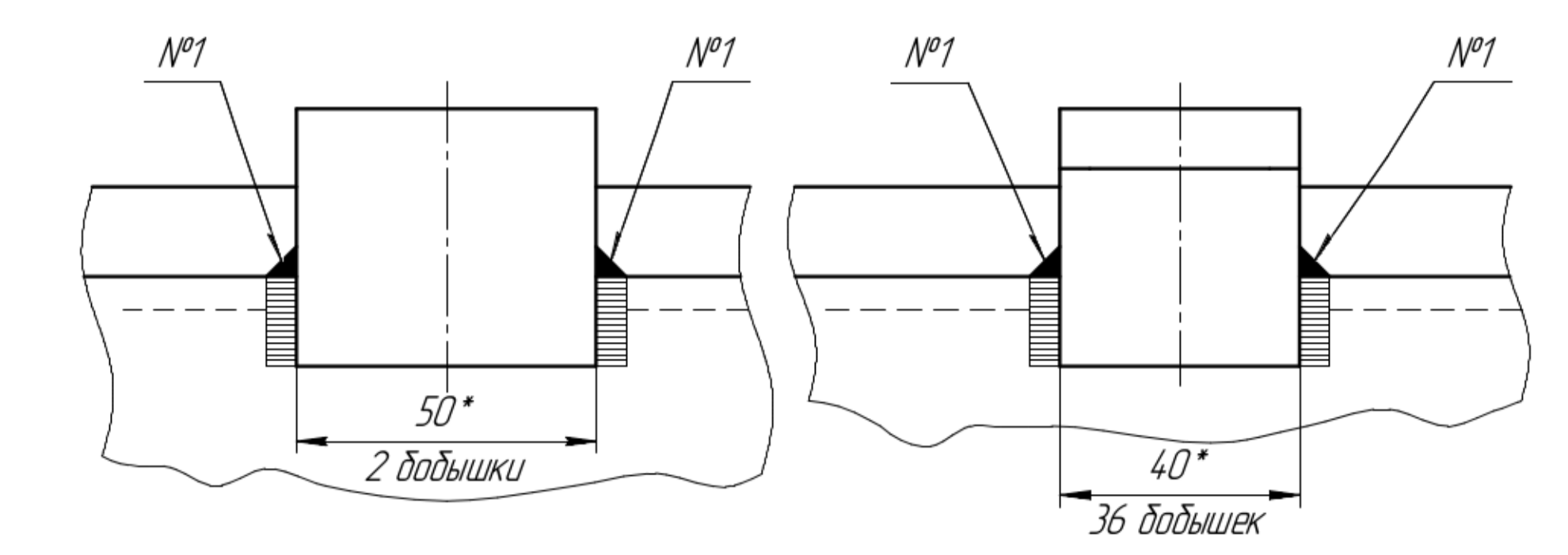

Д(1:2)

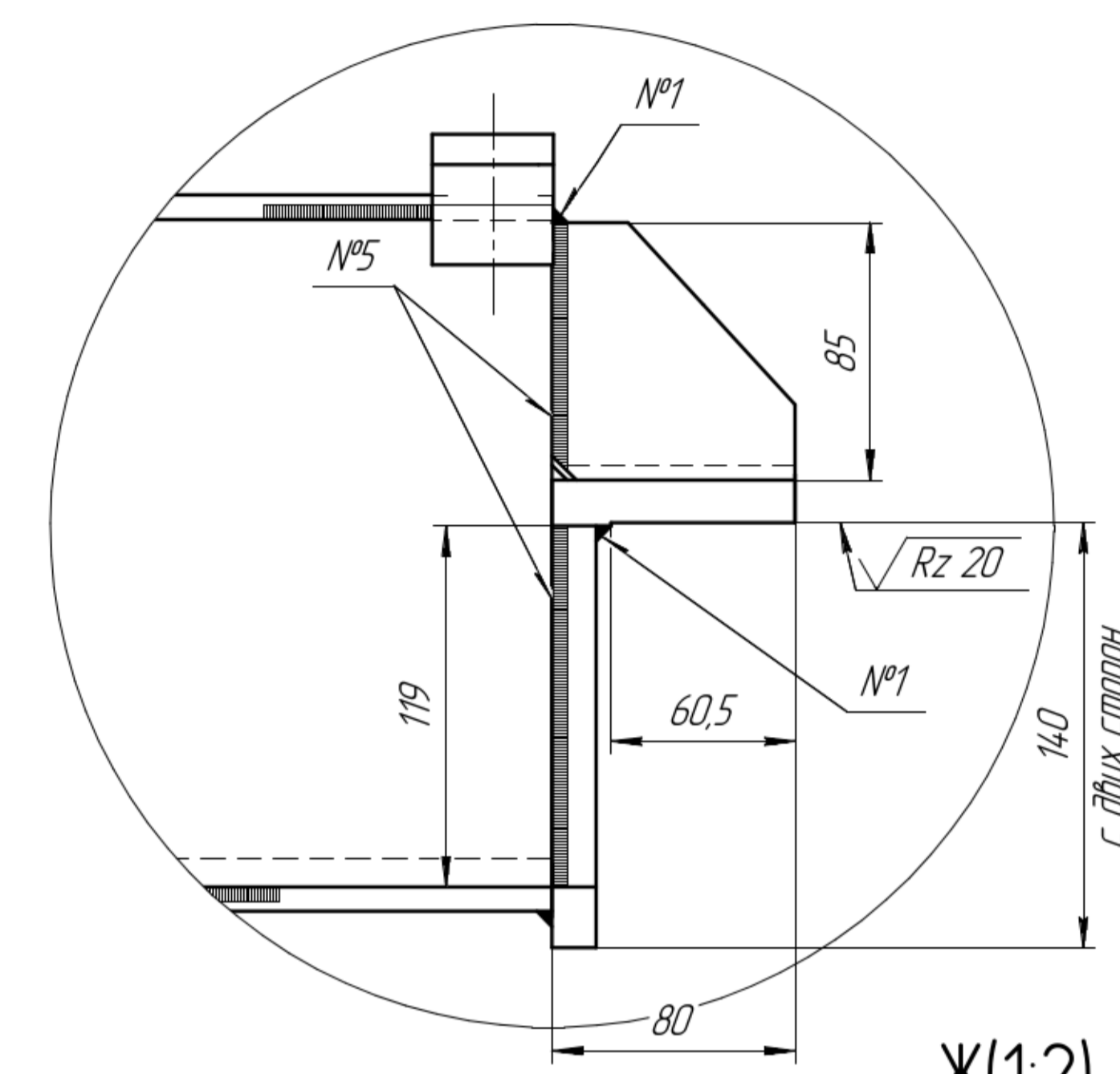

Л-Л(1:2)

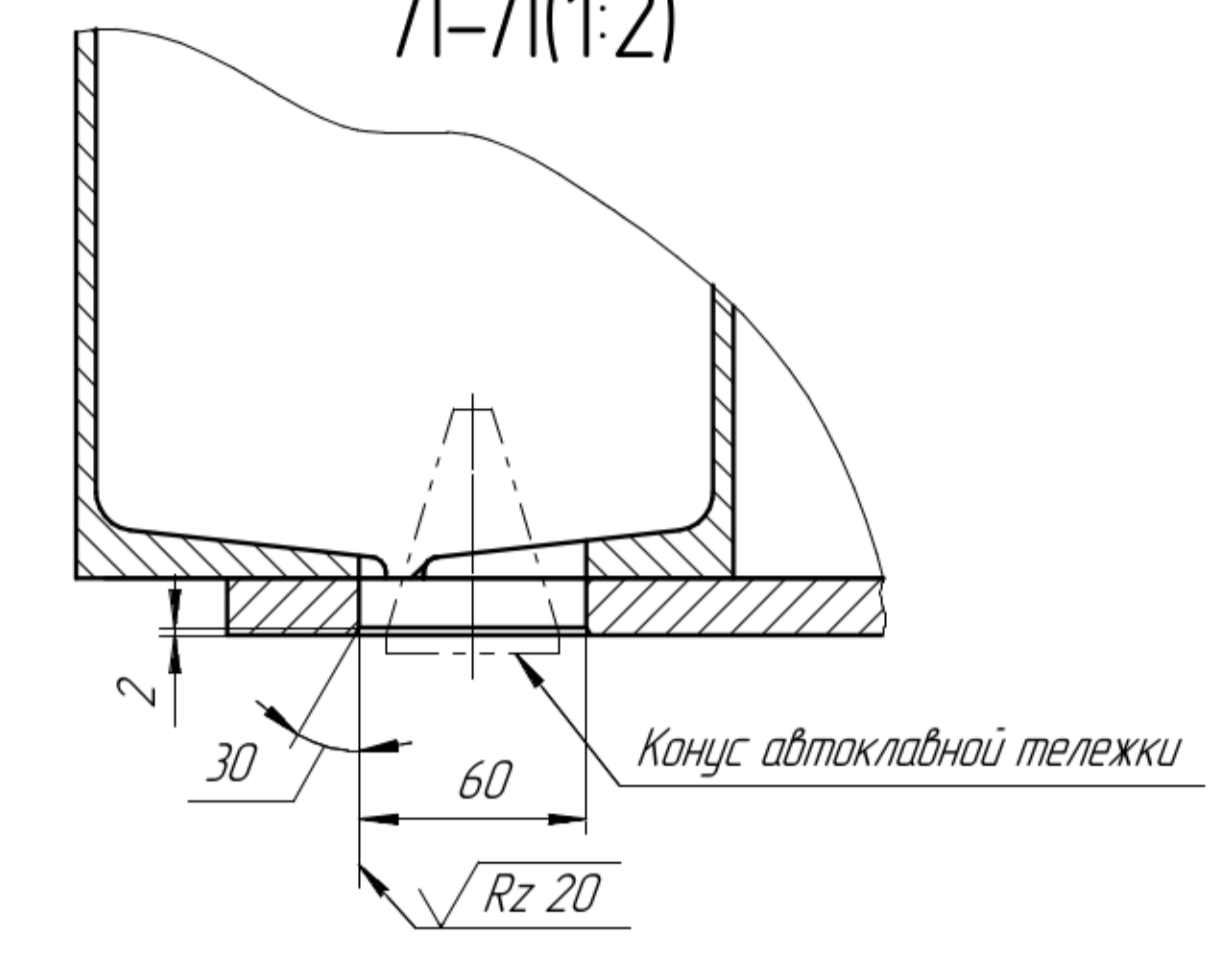

Ж(1:2)

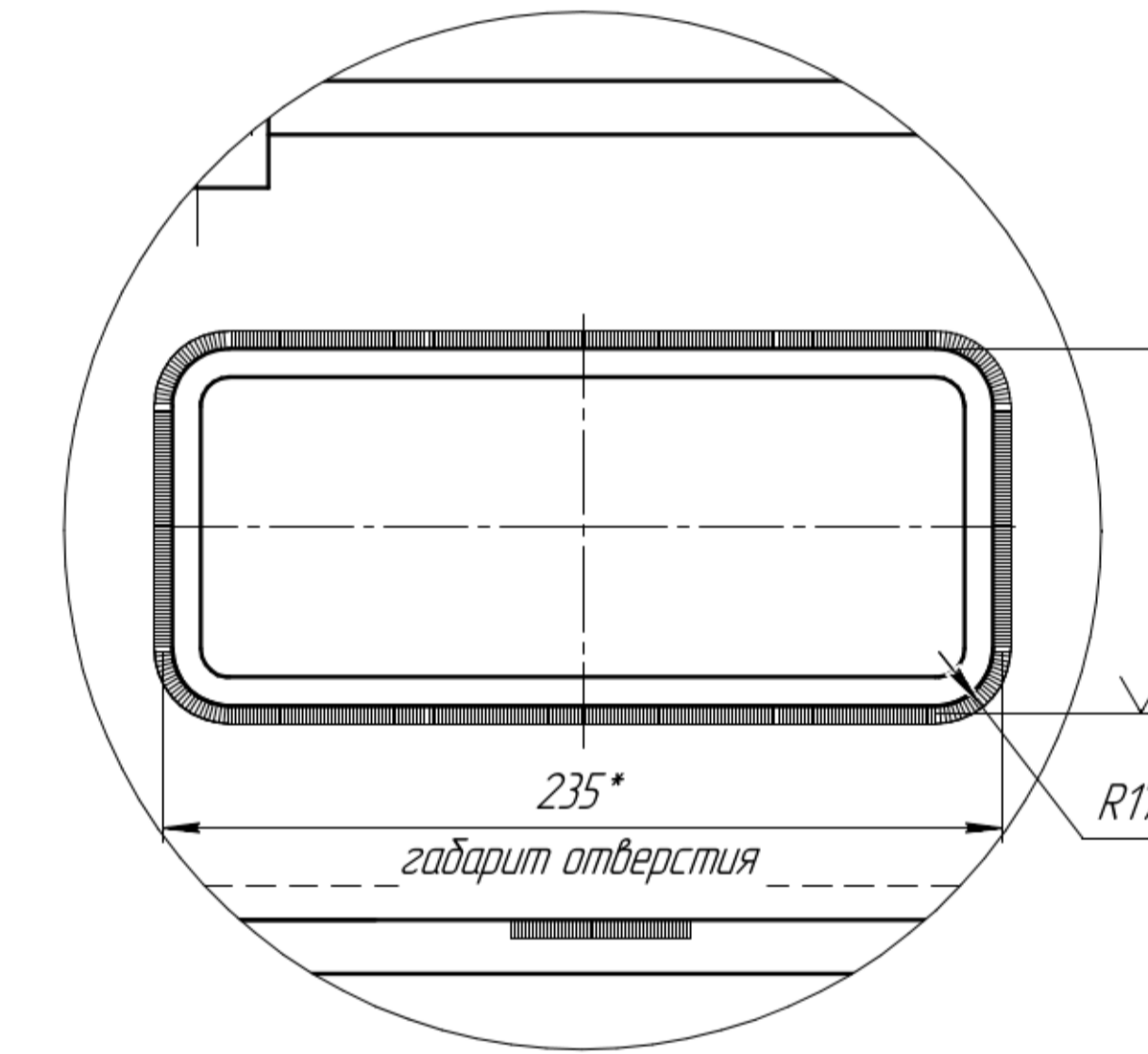

Е(1:2)

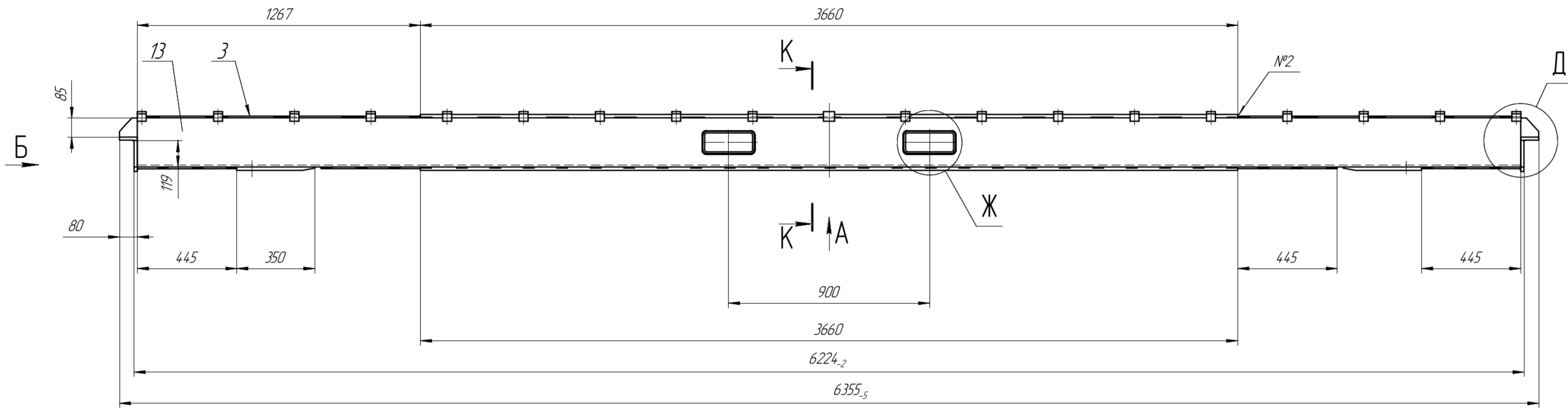
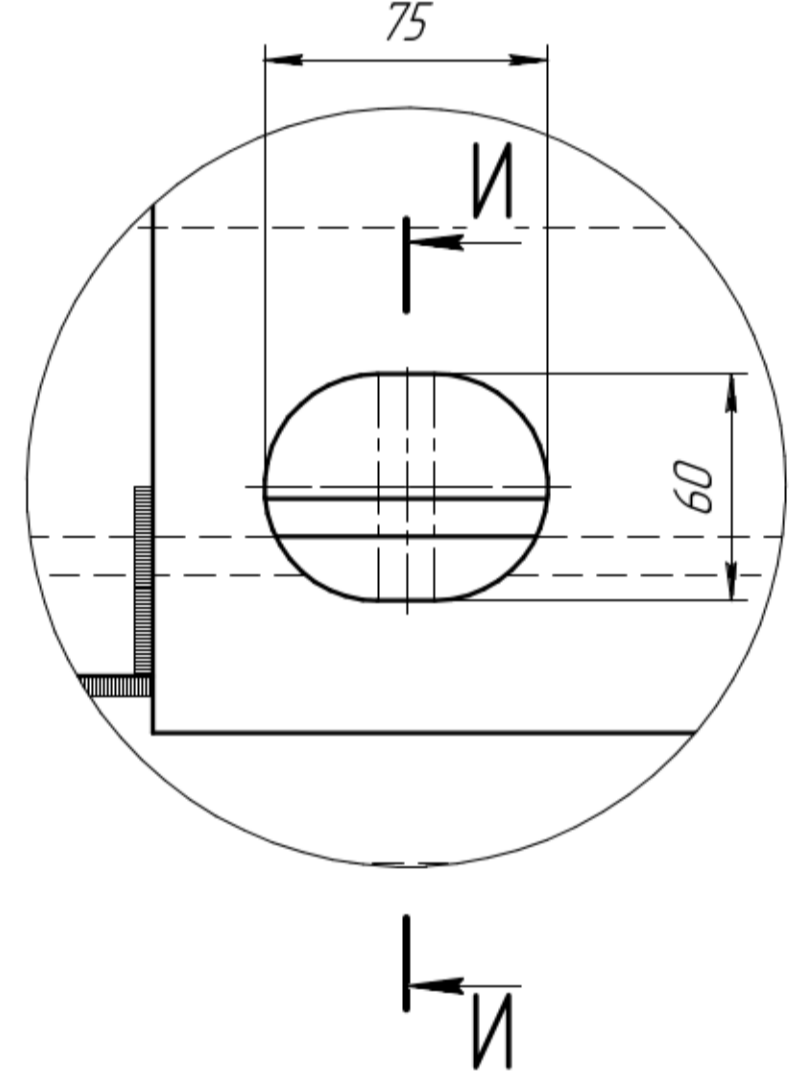

К-К(1:2)

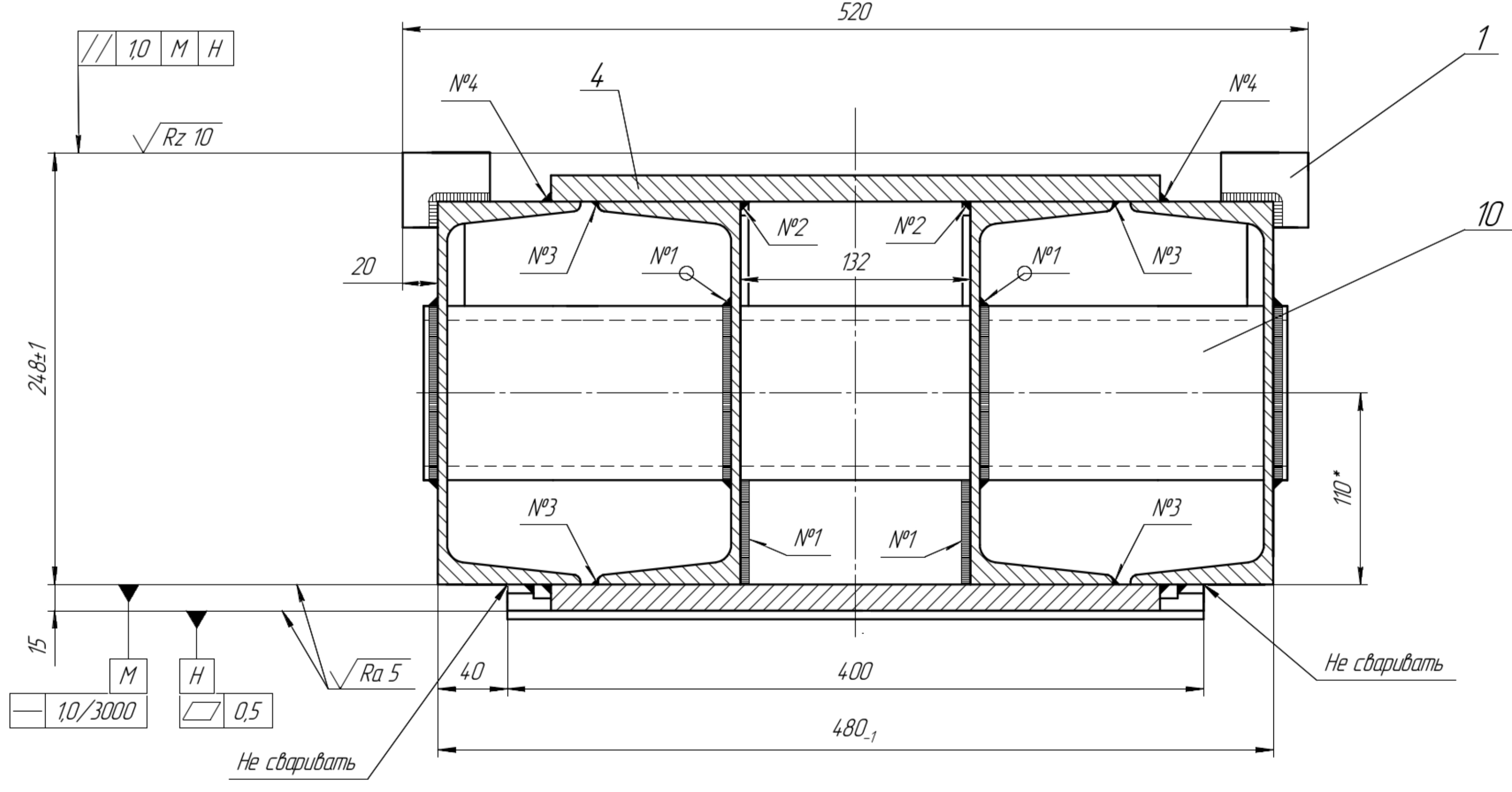

Б(1:2)

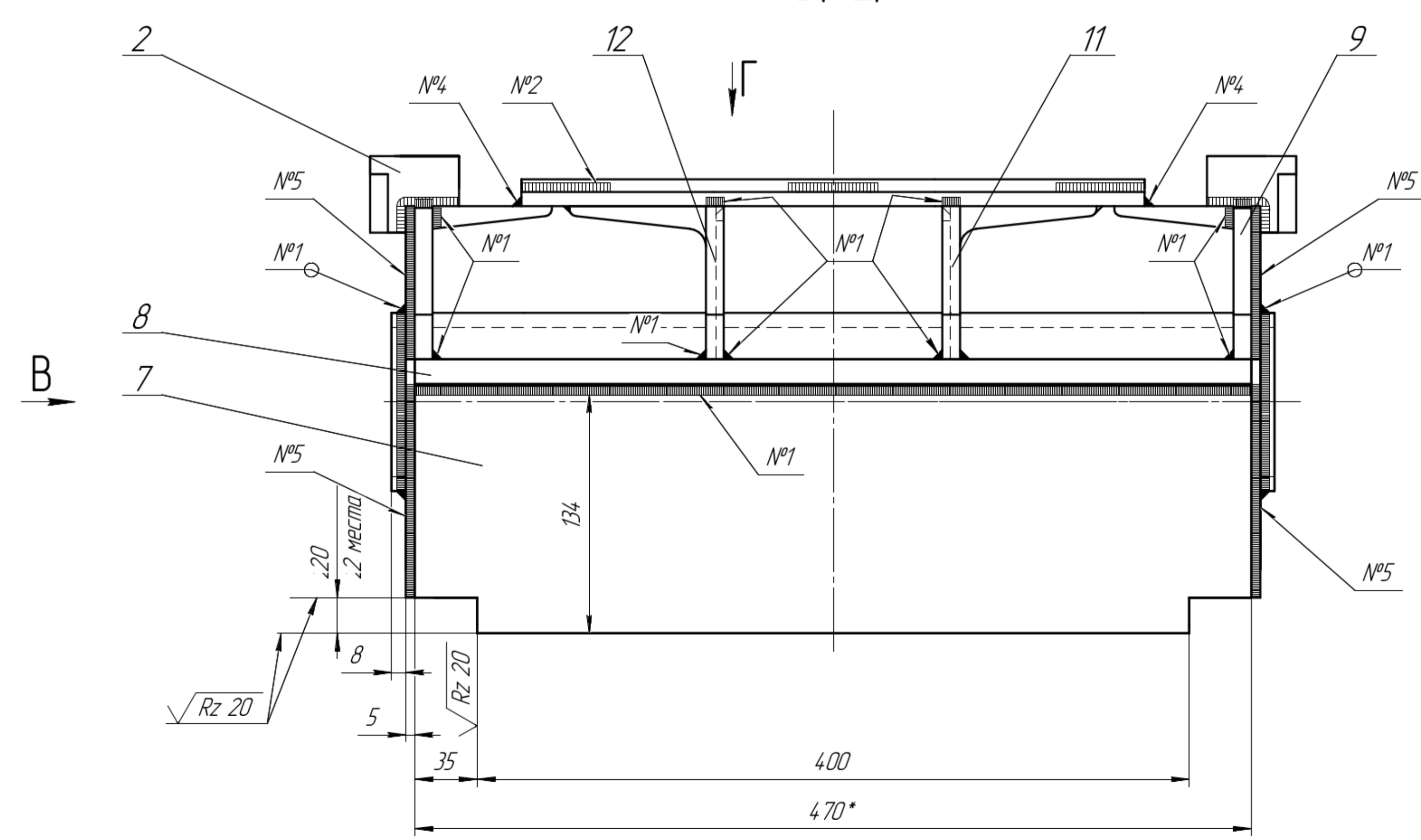

И-И(1:2)

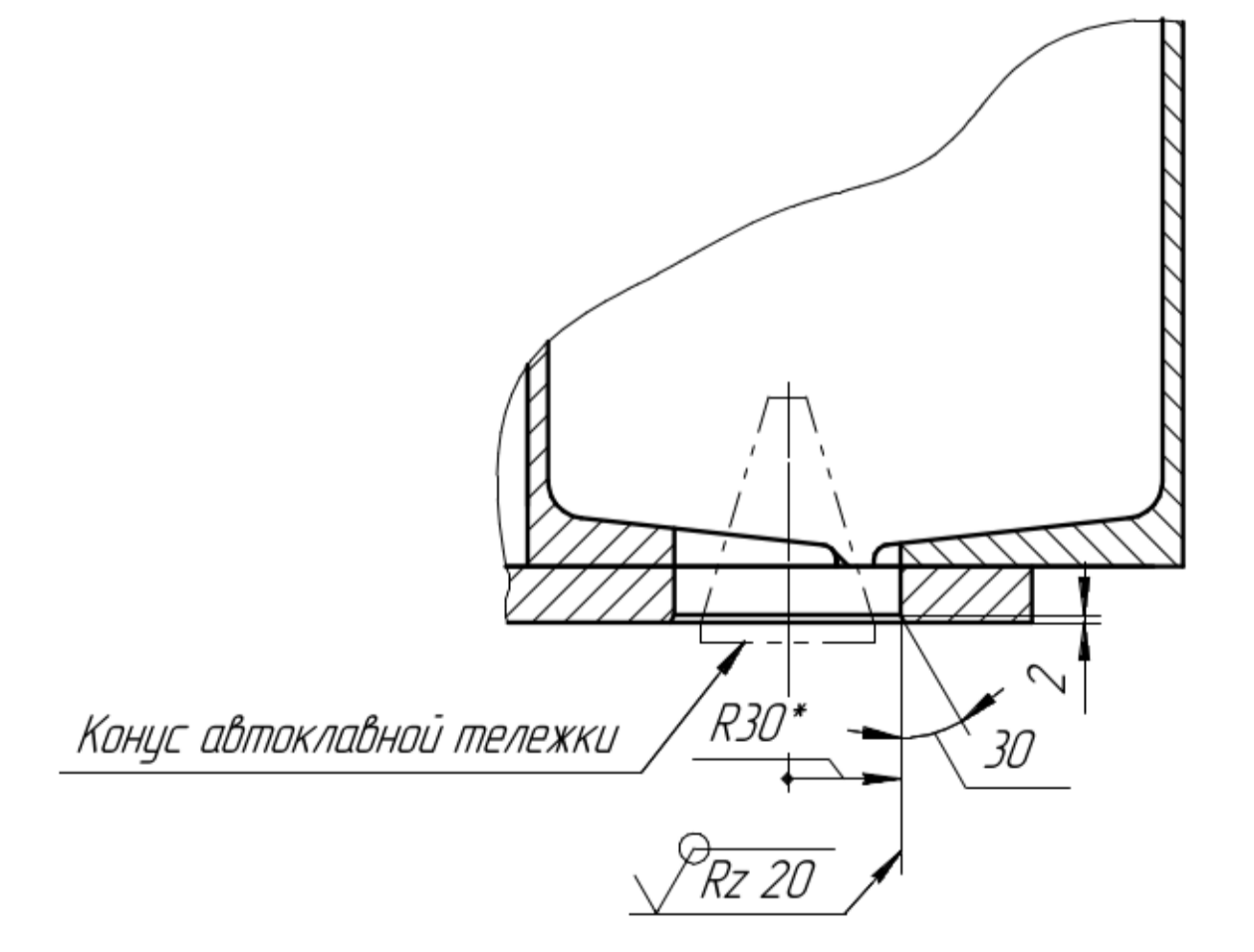

Г(1:2)

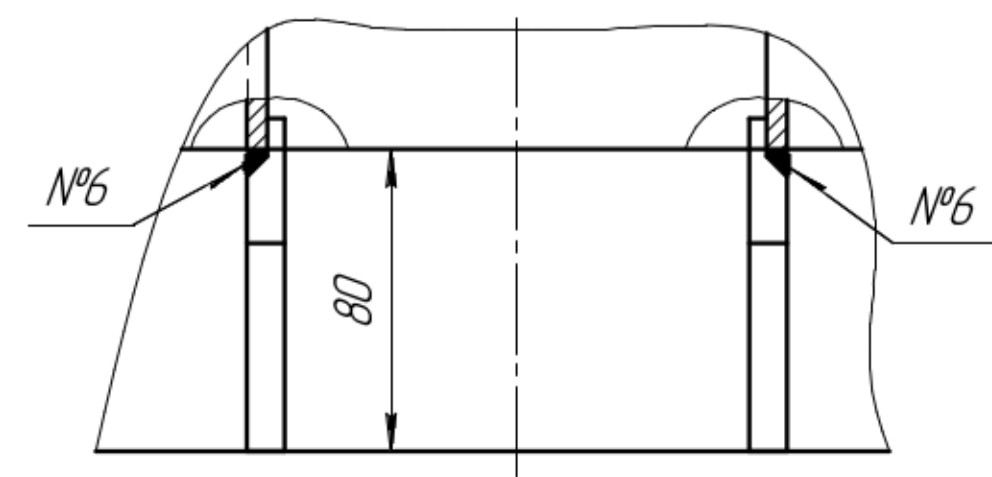

№ шва	Обозначение	ГОСТ	Количество швов	Примечания
№1	T1-5	√Rz20 ГОСТ 5264-80	99	Сварка ручная дуговая
№2	T1-5-50/150	√Rz20	8	-/-
№3	HT-5-50/150	√Rz20	17	-/-
№4	HT-5-100/305	√Rz20	6	-/-
№5	У4	√Rz20	8	-/-
№6	С11	-/-	4	-/-

1. Старые швы по таблице.
2. Общие допуски по ГОСТ 3089311-2002: Н14, н14, ±IT14/2.
3. *Размеры для справок.

EAЖИ6932701000

Рама
Сборочный чертеж

Лист	Масштаб	Максимум
1023	1:10	7

0